

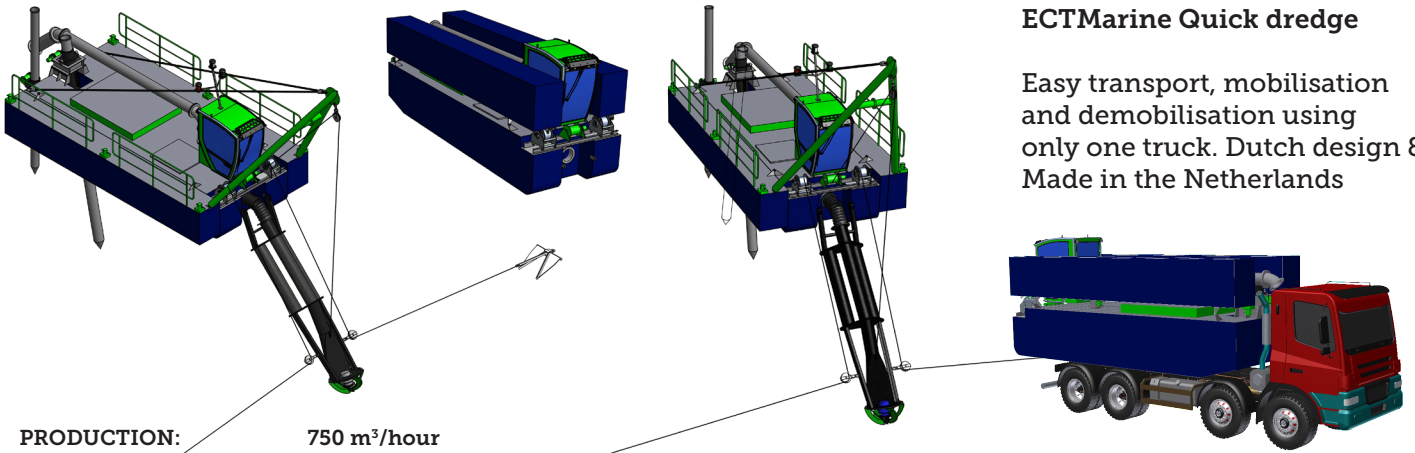

# Leaflet 'Quick dredge 25/170'

## ECTMarine Quick dredge

Easy transport, mobilisation and demobilisation using only one truck. Dutch design & Made in the Netherlands



**PRODUCTION:** 750 m<sup>3</sup>/hour

### DREDGE INSTALLATION

Dredge pump drive	Volvo
Power	175 kW
Dredge pump	8*6
Cutter	ECTMarine 5 Blades
Cutter power	20 kW
Cutter speed	variable 0..30 rpm

Electric installation	
Voltage	24V DC
Electric generator	24 V DC Alternator

### TANK CAPACITIES

Fuel oil	1,5 m <sup>3</sup>
----------	--------------------

### FEATURES

- The dredge pump is a high efficiency single walled abrasion resistant centrifugal pump
- Cutter with multifunctional tooth system with excellent digging performance
- Mobilization and demobilization by single truck
- Heavy duty design
- Low maintenance
- Modular design
- High quality components
- Walking spud system
- Luxurious operator cabin

### MAIN DIMENSIONS

Length overall, ladder up	14	m
Length over pontoons	7	m
Breadth	4	m
Dredging depth	4	m
Suction pipe diameter	300	DN
Discharge pipe diameter	250	DN

### WINCHES

Ladder winch		
Line pull first layer	15	kN
Speed	0..20	m/min
Swing winches (2x)		
Wire pull first layer	15	kN
Hauling speed	0..20	m/min
Anchors (each)	100	kg

### OPTIONAL EQUIPMENT

- Production measurement
- Dredge monitoring tracking system
- Floating pipeline
- Airconditioning
- Plain suction dredger
- Truck with loading system



